

DAMPE silicon tracker on-board data compression algorithm^{*}

DONG Yi-Fan(董亦凡)^{1,2} ZHANG Fei(张飞)¹ QIAO Rui(乔锐)¹ PENG Wen-Xi(彭文溪)^{1;1)}
 FAN Rui-Rui(樊瑞睿)¹ GONG Ke(龚轲)¹ WU Di(吴帝)¹ WANG Huan-Yu(王焕玉)^{1;2)}

¹ Key Laboratory of Particle Astrophysics, Institute of High Energy Physics, Chinese Academy of Sciences, Beijing 100049, China
² University of Chinese Academy of Sciences, Beijing 100049, China

Abstract: The Dark Matter Particle Explorer (DAMPE) is an upcoming scientific satellite mission for high energy gamma-ray, electron and cosmic ray detection. The silicon tracker (STK) is a subdetector of the DAMPE payload. It has excellent position resolution (readout pitch of 242 μm), and measures the incident direction of particles as well as charge. The STK consists of 12 layers of Silicon Micro-strip Detector (SMD), equivalent to a total silicon area of 6.5 m^2 . The total number of readout channels of the STK is 73728, which leads to a huge amount of raw data to be processed. In this paper, we focus on the on-board data compression algorithm and procedure in the STK, and show the results of initial verification by cosmic-ray measurements.

Key words: silicon tracker, silicon micro-strip detector, data compression

PACS: 95.55.-n **DOI:** 10.1088/1674-1137/39/11/116202

1 Introduction

The Dark Matter Particle Explorer (DAMPE) is a space science mission of the Chinese Academy of Sciences. The major scientific objective of DAMPE is to measure electrons and photons in the energy range of 5 GeV–10 TeV with unprecedented energy resolution (1.5% at 100 GeV) in order to explore the possible signatures of dark matter [1]. It will also measure the spectra of nuclei up to above 500 TeV. The DAMPE payload is composed of four subdetectors as shown in Fig. 1: 1) Plastic Scintillator Detector (PSD); 2) Silicon Tracker (STK); 3) BGO calorimeter (BGO) and 4) Neutron Detector (NUD)

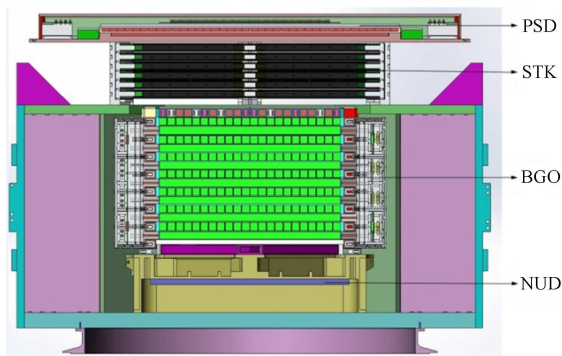

Fig. 1. (color online) DAMPE cross section.

The main purpose of the silicon tracker is to measure the incident direction of particles, as well as the charge ($Z=1-26$). To achieve these goals, a mature technique of silicon micro-strip detectors with high spatial resolution is implemented. Besides, the gamma-ray photons can also be measured by converting them to electron/positron pairs in heavy- Z material (tungsten) within the STK.

In this paper, we first introduce the system structure of the silicon tracker, the data acquisition architecture, and the requirements for data compression. The on-board data compression based on hardware design is then presented. Finally, an initial verification test is shown.

2 The silicon tracker

The STK consists of six tracking detector planes, each plane having two layers (X , Y direction) of silicon detectors with orthogonally oriented strips. Three layers of tungsten plates with thickness of 1.0 mm are inserted in front of tracking planes 2, 3 and 4 for photon conversion. The silicon detectors are single-sided, AC-coupled, 320 μm thick, 95 mm \times 95 mm in area, and segmented into 768 strips with a 121 μm pitch. Four detectors are glued head-on together and wire bonded one after the other along the direction of the strips to form a

Received 3 March 2015

^{*} Supported by Strategic Priority Research Program on Space Science of Chinese Academy of Sciences (XDA040402) and National Natural Science Foundation of China (1111403027)

1) E-mail: pengwx@ihep.ac.cn

2) E-mail: wanghy@ihep.ac.cn

©2015 Chinese Physical Society and the Institute of High Energy Physics of the Chinese Academy of Sciences and the Institute of Modern Physics of the Chinese Academy of Sciences and IOP Publishing Ltd

ladder, and then glued to the Tracker Front-end Hybrid (TFH) where the readout ASICs and associated circuits are integrated. The readout ASIC is a VA140 chip designed by Gamma Medica, which is a 64-channel, low noise, high dynamic range charge sensitive preamplifier-shaper circuit [2]. The VA140 has simultaneous sample and hold, multiplexed analog readout. On each TFH, there are 6 VA140s to read out 384 strips; only every other strip will be read out. Since analog readout is used as required for charge measurement, however, the position resolution can be optimized thanks to charge sharing on floating strips. Each layer has 16 ladders and covers an area about $76\text{ cm} \times 76\text{ cm}$. Figure 2 shows the arrangement of ladders of the six X -view layers.

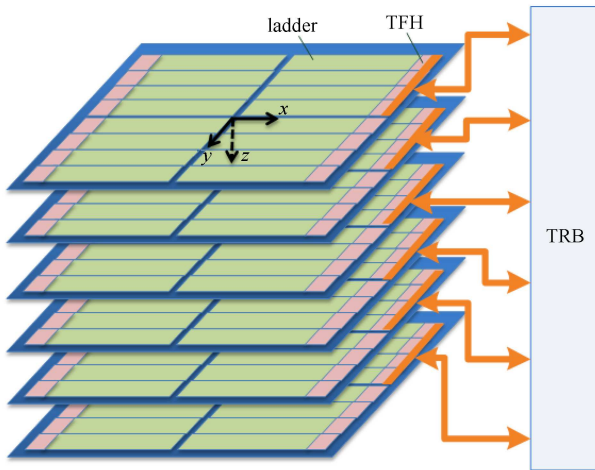

Fig. 2. (color online) Ladder arrangement and connection of 6 X -view layers.

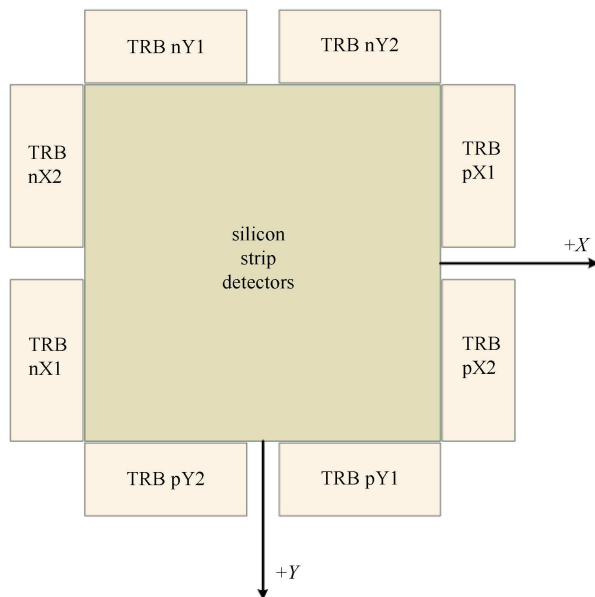

Fig. 3. (color online) Top view of the STK.

The ladders are connected via flexible cables to the Tracker Readout Boards (TRBs) surrounding the tracking planes, where the ADCs, monitor circuits, high-voltage generator and control logics are situated. The TRBs are in charge of data acquisition and status monitoring of the silicon tracker. On one hand they receive triggers and configuration commands from payload DAQ and on the other hand they transfer scientific data and house-keeping data back. There are eight TRBs in all at four vertical sides of the STK, as presented in Fig. 3. Each TRB reads out one quarter of the ladders of all six layers at the same side, as Fig. 2 shows. The system block diagram is shown in Fig. 4.

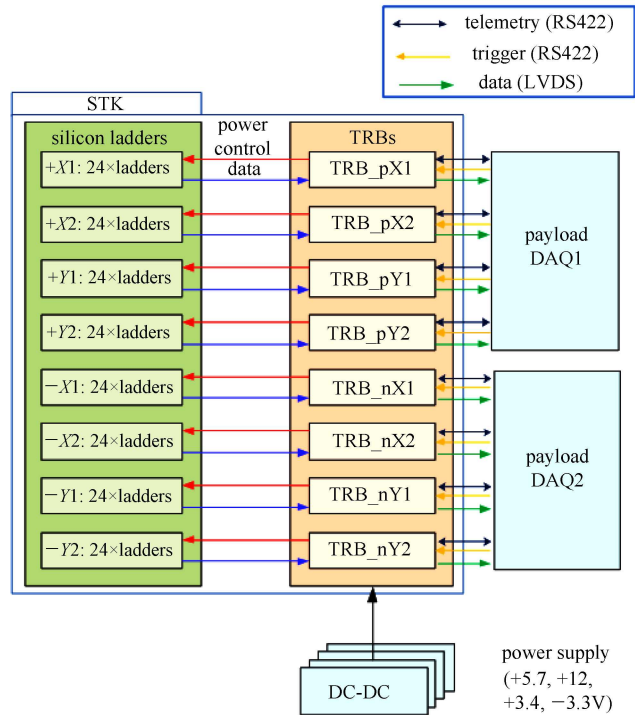

Fig. 4. (color online) System block diagram of the STK.

3 Data compression requirements and challenges

As described above, the STK has 73728 analog readout channels in total. The analog signal of each channel will be digitalized by 12-bit ADC on TRB to give 2 bytes for each event. According to physics simulations, the mean trigger rate in-orbit of DAMPE is 50 Hz [3], therefore STK will create 637 GB of raw data per day. However the downlink capability of the satellite is only 10 GB per day for all the payloads so it is impossible to download all the raw data from the STK.

On the other hand, in most cases, for each event, only several readout strips are fired due to a particle hit; other

channels only have noise (zero channel) [4], which should be removed from the real data. This processing method is called data compression or zero compression.

There are already similar detectors in space which have data compression on-board such as the AGILE silicon tracker which uses the TAA1 readout ASIC. The TAA1 ASIC contains a threshold discriminator per readout channel, and a trigger signal is generated from the OR of all channels of a TAA1 [5]. The ASICs which are full of empty channels can then be ignored directly before readout, reducing the raw data quite a lot and making the data compression much simpler. However, the DAMPE STK employs the VA140 readout ASIC without self-trigger to meet the strict limits on power consumption. It is noted that the triggers are generated by the BGO calorimeter [6], so the STK cannot distinguish fired channels from zero ones before reading out all channels, and as a result, it has to process all channels.

Furthermore, AGILE has CPUs for data compression but the DAMPE STK has only two FPGAs on each TRB to process about twice the number of readout channels as AGILE. Consequently, the DAMPE STK confronts more difficulties in compressing the data.

4 Data acquisition architecture

In the STK, the data compression is done by two FPGAs on each TRB, which also implement all the other logics (controlling readout ASICs, monitoring status and communicating with payload DAQ). Both FPGAs are APA1000 flash FPGA from Actel. Each FPGA takes charge of 12 ladders connected to its TRB. The six VA140 ASICs on each TFH are divided into two groups. In each group, the signals of 192 channels (each ASIC has 64 channels) are output in series and digitized.

At every trigger, each FPGA takes in the data from 24 ADCs in parallel 192 times, getting the raw data of 4608 channels written into the first level cache F_RAM in FPGA Fig. 5. Then pre-processing of data is run, and the results are stored in F_RAM as well because of the source limitation on the FPGA. Every two ladders share an F_RAM unit and each F_RAM unit can be accessed independently so that the pre-processing is in parallel by two ladders. After that, cluster finding is done ladder by ladder, which seeks out the fired channels within some boundary conditions. Once the step of cluster finding in a ladder is complete, the compressed data will be trans-

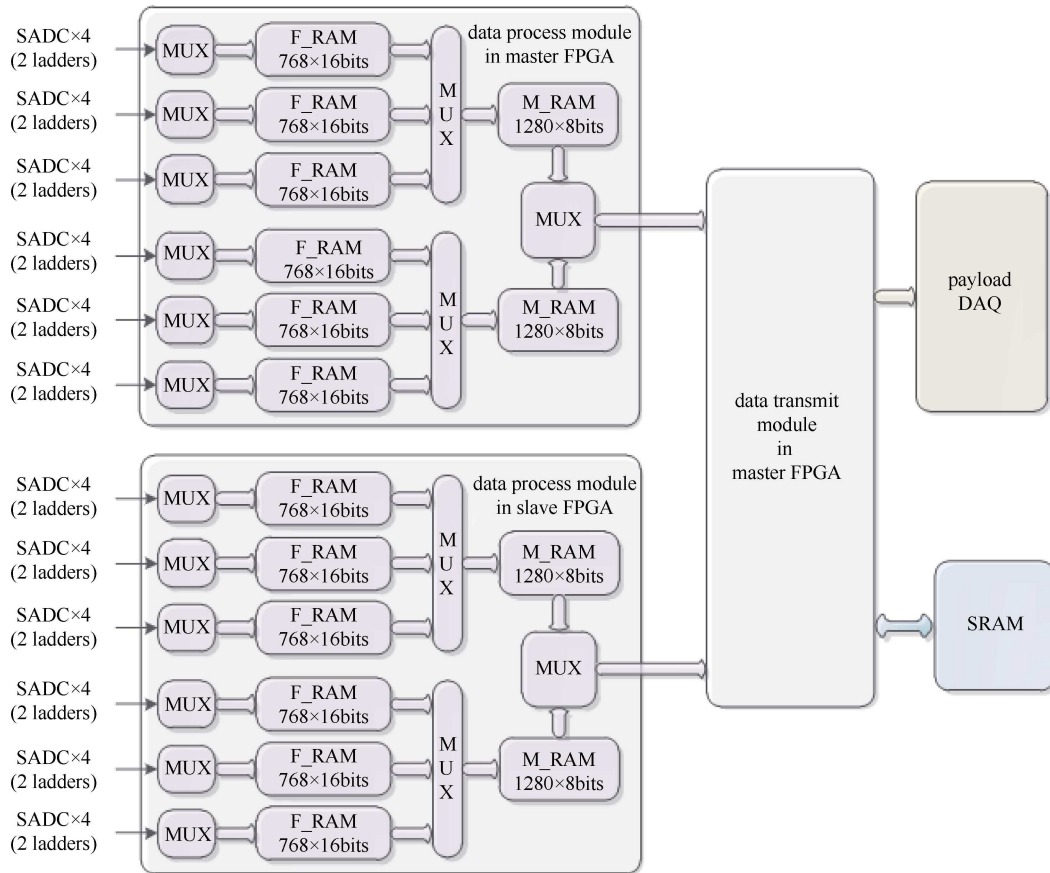

Fig. 5. (color online) Data acquisition architecture.

ferred to the second level cache M_RAM. Finally, the data will be packaged in the final format and stored into external SRAM. All these procedures can be finished in 3 ms, after which the first and second level cache will be released and the STK is ready for the next event.

Generally, the SRAM has the capacity for tens of events in the worst case, the data in the SRAM will be transmitted to the payload DAQ at a certain time after every trigger.

5 On-board data compression algorithm and procedure

5.1 Pre-processing

5.1.1 Pedestal subtraction

The pedestal of a channel is its base level without signal, which is determined by the property of the readout ASIC and the bias. It is defined as:

$$\text{ped}_i = \frac{1}{N} \sum_{j=1}^N \text{ADC}_{ij}, \quad (1)$$

where ADC_{ij} is the digitized value of each channel i in the event j with a random trigger. Fig. 6 shows a typical pedestal distribution for an STK ladder.

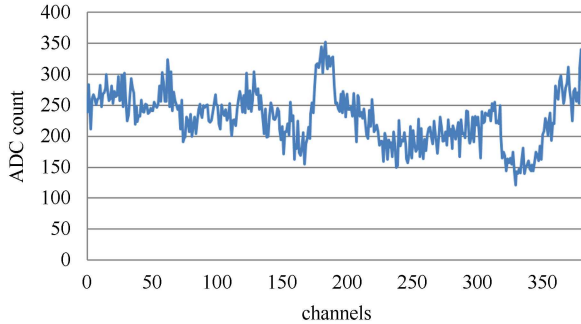

Fig. 6. (color online) Pedestal of a ladder.

There is a pedestal updating procedure in FPGA to calculate the pedestals onboard using 1024 random triggers. It operates twice every orbit cycle and the computed pedestal values are stored in the TRB.

During the observation mode of STK, the first step of data compression is to subtract the pedestals from the raw ADC values. The results will first replace the raw ADC values in the F_RAM cache and then act as input in the next step.

5.1.2 Common mode noise subtraction

The common mode noise (CN) is the deviation of all the channels of a readout ASIC at the same time mainly because of the fluctuation of the bias voltage. For each ASIC, the common mode noise of event j is calculated

as

$$CN_j = \frac{1}{N_j} \sum_i^{N_j} (\text{ADC}_{ij} - \text{ped}_i), \quad (2)$$

where N_j is the number of good strips within the ASIC (noisy or dead strips need to be excluded). Figure 7 shows a typical distribution of the common noise of a ladder. Usually N_j is 64 for the STK, the total channel number of the VA140, but if bad strips exist (as seen in Fig. 8 and Fig. 9), it is hard to calculate CN in the FPGA when N_j is no longer a power of 2. As a solution in the FPGA, the CN is actually computed with 32 good channels, which is almost the same as with 64 good channels. For worse case when the number of bad channels is more than 32, the CN can be computed with 16 good channels automatically. If most (>48) of the channels are bad, however, all channels of the ASIC will be blocked.

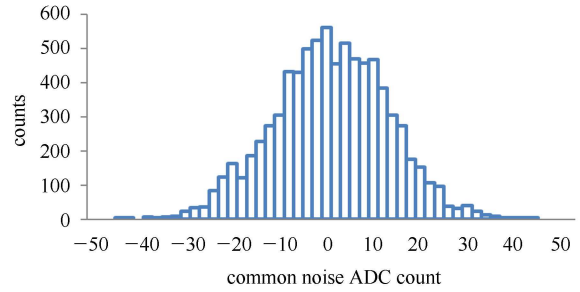

Fig. 7. (color online) Common mode noise distribution of a ladder.

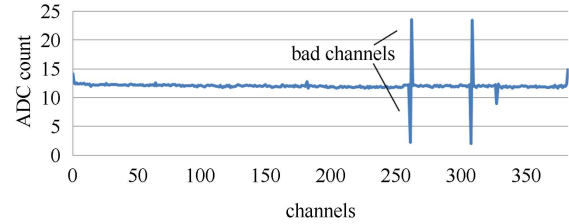

Fig. 8. (color online) Sigma with CN .

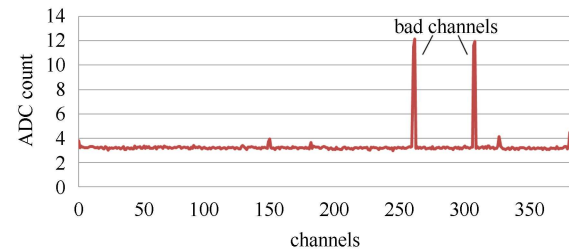

Fig. 9. (color online) Sigma without CN .

The influence of CN on the sigma value is shown in Fig. 8 and Fig. 9. A too high CN could produce noise obscuring the signals. In the second step of data pre-processing, the CN will be computed for each event and subtracted replacing the results in the memory of the last step.

5.1.3 Bad channel cut

So far the reduced values in the memory are

$$r_{ij} = \text{ADC}_{ij} - \text{ped}_i - CN_j. \quad (3)$$

In the last step of pre-processing, a bad channel cut is applied to the reduced values by writing them to zero which will certainly be excluded in cluster finding. The bad channels are identified by a bad channel list stored onboard, which can be modified by sending telemetry commands from the ground.

In addition, the pedestals of all channels calculated and stored on-board for pedestal cutting are provided with an odd check. If the pedestal of a channel is mistaken because of single event upset (SEU), the reduced value of the channel will also be written to zero in this step because the subtracted pedestal is unreliable.

5.2 Cluster finding

A cluster is a group of neighboring strips which share the charge induced by the energy deposited by the particle Fig. 10. These strips are those fired which need to be found out and kept in the compressed data. Cluster finding begins with the traversing of the reduced values in the memory and seeking of the cluster seed. A cluster seed is a channel with the reduced value $r_{ij} > Ts_i$, where the Ts_i is the seed threshold of the channel i . When there is a cluster seed, the channels before and behind are checked with an identical fire threshold Tf , until $r_{ij} < Tf$. The whole cluster is from the first channel to the last channel for which $r_{ij} \geq Tf$, with at least one channel having $r_{ij} > Ts_i$ within the cluster.

The address of the first channel of the cluster and the reduced value of each channel are saved in the compressed data. Since the channels are continuous, the address of the first channel is sufficient to get the hit information.

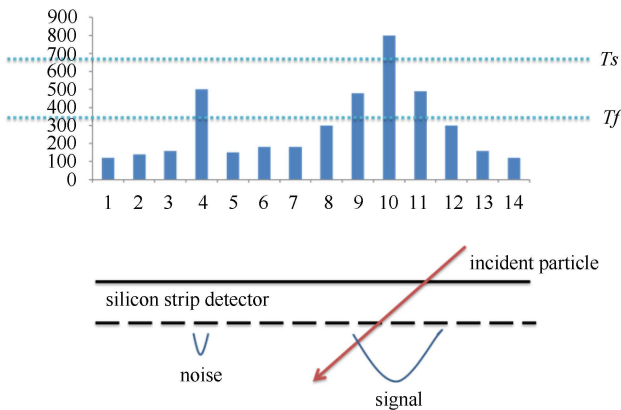

Fig. 10. (color online) Cluster finding.

In addition to the observation mode with data compression, the STK also has a raw data mode running for

inflight calibration. The sigma of each channel can be computed from the raw data, using

$$\sigma_i = \sqrt{\frac{1}{N} \sum_{j=1}^N (\text{ADC}_{ij} - \text{ped}_i - CN_j)^2}, \quad (4)$$

where ped_i and CN_j are computed as noted. The seed thresholds and fire thresholds, which should be a multiple of the sigma, are decided offline and sent to the STK for modification by telemetry commands.

In this algorithm, the data compression ratio is related to the number of clusters per event and the number of strips per cluster. According to the STK physical simulation [4], the average number of clusters per event is 190 and the average number of strips per cluster is 3, thereby the total compressed data per day with 50 Hz trigger rate will be 6.3 GB, which is less than 1% of the raw data volume.

6 Test results with cosmic muons

The on-board data compression procedure has been tested by measuring cosmic muons. The trigger is generated from an additional plastic scintillator on top of

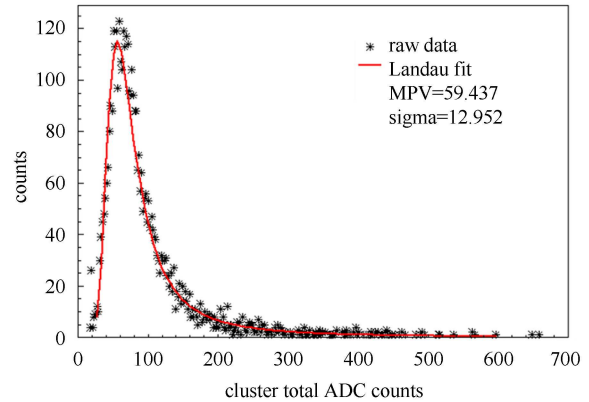

Fig. 11. (color online) Cosmics spectrum of raw data.

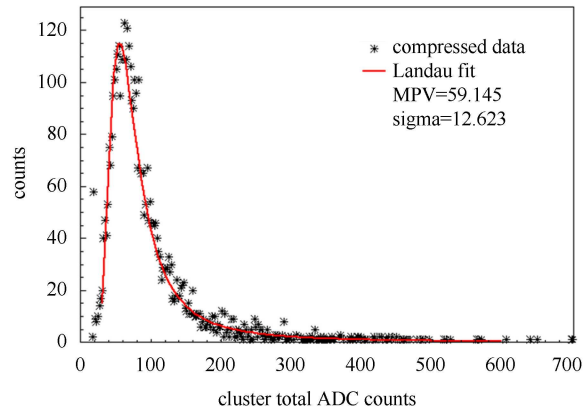

Fig. 12. (color online) Cosmics spectrum of compressed data.

the silicon ladder. The same number of raw data events and compressed data events are compared, and the results are shown in Fig. 11 and Fig. 12. A Landau fit is used to obtain the most probable value and the sigma of the MIPs peak; the cluster energy spectrum of raw data and compressed data agree quite well which shows that the data compression keeps the correct information.

7 Summary

The silicon tracker of DAMPE uses silicon micro-

strip detectors to achieve an excellent position resolution, which results in a huge number of readout channels and thus a huge amount of raw data. Because of the downlink limitation of the satellite, on-board data compression is required for the STK, which is challenging to accomplish with restricted on-board resources. This paper presents the data acquisition architecture and the data compression algorithm and procedure of the STK. The initial test results with cosmic muons demonstrate that the on-board data compression of the STK is valid and effective.

References

- 1 CHANG Jin. *Chin. J. Space Sci.*, 2014, **34**(5): 550–557
- 2 Gamma Medica-Ideas. VA140 documentation(VR1) 2011
- 3 The trigger and DAQ in DAMPE. DAMPE Workshop. June 2013
- 4 WU Xin. Triggering on (Low Energy) Photons and Data Volume of STK. DAMPE Workshop November, 2013
- 5 Bulgarelli A et al. *Nucl. Instrum. Methods A*, 2010, **614**: 213–226
- 6 FENG Chang-Qing et al. Prototype Design of DAMPE Calorimeter Readout Electronics and Performance in CERN Beam test. 40th. COSPAR Scientific Assembly. Moscow, 2014