

Development of the liquid level meters for the PandaX dark matter detector^{*}

HU Jie(胡捷)^{1;1)} GONG Hao-Wei(龚昊伟)¹ LIN Qing(林箐)¹ NI Kai-Xuan(倪凯旋)^{1;2)} TAN An-Di(谈安迪)²
WEI Yue-Huan(魏月环)¹ XIAO Meng-Jiao(肖梦蛟)¹ XIAO Xiang(肖翔)¹ ZHAO Li(赵力)¹

¹ Department of Physics and Astronomy, Shanghai Jiao Tong University, Shanghai 200240, China

² Department of Physics, University of Maryland, College Park, MD 20742, U.S.A.

Abstract: The two-phase xenon detector is at the frontier of dark matter direct search. This kind of detector uses liquid xenon as the sensitive target and is operated in two-phase (liquid/gas) mode, where the liquid level needs to be monitored and controlled in sub-millimeter precision. In this paper, we present a detailed design and study of two kinds of level meters for the PandaX dark matter detector. The long level meter is used to monitor the overall liquid level while short level meters are used to monitor the inclination of the detector. These level meters are cylindrical capacitors that are custom-made from two concentric metal tubes. Their capacitance values are read out by a universal transducer interface chip and are recorded by the PandaX slow control system. We present the developments that lead to level meters with long-term stability and sub-millimeter precision. Fluctuations (standard deviations) of less than 0.02 mm for the short level meters and less than 0.2 mm for the long level meter were achieved during a few days of test operation.

Key words: liquid level meter, xenon, dark matter

PACS: 07.07.Df, 95.35.+d, 29.40.-n **DOI:** 10.1088/1674-1137/38/5/056002

1 Introduction

Liquid xenon (LXe) is currently used as a suitable target for direct detection of the weakly interacting massive particles (WIMPs) dark matter [1, 2]. In a xenon detector operated in two-phase mode, the LXe level in the time projection chamber (TPC) is an important parameter for the experiment and the liquid level needs to be monitored and controlled in sub-millimeter precision [3]. In order to monitor the liquid level precisely for the detector operation, level meters working at the LXe temperature (around 178 K) are constructed and measurement methods are developed for the PandaX dark matter detector. These level meters are all custom-made concentric cylindrical capacitors.

As shown in Fig. 1, a long level meter is used to monitor the total LXe level in the inner vessel of the detector, which is used during the filling and recovery of the liquid xenon. Three short level meters are mounted at the height of the liquid-gas interface around the TPC to monitor its declination, which is important to maintain a uniform gas gap across the horizontal plane for

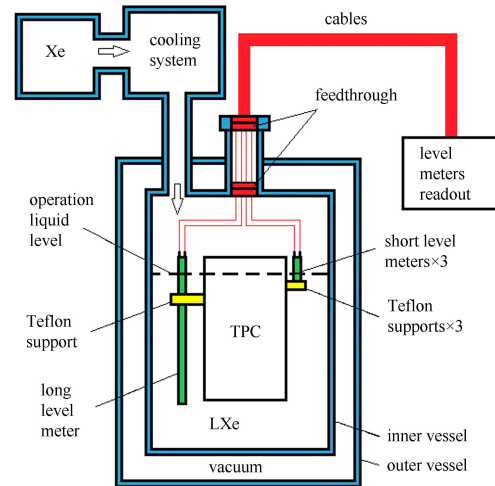

Fig. 1. Schematics of the two-phase xenon detector as used in PandaX. LXe is contained in an inner vessel insulated by vacuum from the outside. One long liquid level meter monitors the overall liquid xenon height and three short level meters monitor the height of the liquid-gas interface around the TPC.

Received 17 June 2013

^{*} Supported by National Science Foundation of China (11055003, 11175117), Science and Technology Commission of Shanghai Municipality (11PJ1405300) and Ministry of Science and Technology of China (2010CB833005)

1) E-mail: hujiedhu@hotmail.com

2) E-mail: nikx@sjtu.edu.cn

©2014 Chinese Physical Society and the Institute of High Energy Physics of the Chinese Academy of Sciences and the Institute of Modern Physics of the Chinese Academy of Sciences and IOP Publishing Ltd

homogeneous signals. In Section 2 we present the detailed design and method of the level meter fabrication and readout. The results during a few days of operation in a test xenon detector are reported in Section 3. We conclude, in Section 4, that the level meters can reach the sub-millimeter precision and stability that are required by the detector's operation.

2 Design and methods

2.1 Design of the level meters

The short level meter and the long level meter are custom-made concentric cylindrical capacitors, made by two stainless steel tubes nested together with nylon fishing lines wound around the inner tube to separate it from the outer tube. In this study, the Universal Transducer Interface (UTI) sensor chip from Smartec Company [4] is used as a measurement device for the level meters. Considering the measurement range of the UTI sensors, the capacitances of level meters are limited to 12 pF for short level meters and 300 pF for the long level meter in LXe, while the capacitance per unit length should be large enough to obtain a precise measurement. In addition, the dimensions of the level meters should be as small as possible to minimize their influence on the detector.

With these requirements, we design the liquid level meters using two concentric stainless steel tubes with an inner diameter of 4.5 mm for the outer tube and an outer diameter of 4.0 mm for the inner tube. These two tubes are separated by a 0.2 mm diameter nylon fishing line surrounding the inner tube. The length of the short level meters are 12 mm, giving a capacitance of 10.61 pF when it is totally immersed in liquid xenon. The length of the long level meter is 254 mm, giving a capacitance of 232.3 pF when it is totally immersed in liquid xenon. The capacitance per unit length is 0.41 pF/mm for the short level meters and 0.44 pF/mm for the long level meters. Table 1 shows the dimensions of the level meters and their theoretical capacitances when totally immersed in gas xenon (C_{GXe}) or liquid xenon (C_{LXe}). The effect of the nylon lines, which are uniformly distributed in the level meters and occupy 1.57 mm³ in the short level meters and 9.42 mm³ in the long level meter, is considered for the estimation of capacitances. The assembled level meters are shown in Fig. 2.



Fig. 2. A photo showing an assembled 12 mm short level meter (*SLM*) and a 254 mm long level meter (*LLM*), made with two concentric stainless steel tubes.

2.2 Cable connections

Since the relative large parasitic capacitance caused by long cables connected parallel to the capacitors, it is difficult to obtain a small capacitance accurately by direct measurement. The UTI sensor chip uses the principle of four-wire measurement to overcome the problem of parasite capacitances and three-signal technique for auto-calibration. The company provides an evaluation board that has several different measurement modes for capacitances, Pt-100 temperature sensors, electric bridges etc. [4]. In this study, we use mode 2 to measure the three capacitors in the range of 0–12 pF for the three short level meters simultaneously and mode 4 to measure the single capacitor in the range of 0–300 pF for the long level meter.

The schematics to use mode 2 to measure the three capacitances for the short level meters are shown in Fig. 3. A reference capacitor with unchanging capacitance is needed for this mode. We used a 12 pF reference capacitor made with the same method as the other short level meters, but which was twice as long. It is placed in the gas xenon just above the liquid surface in order to cancel the interference in the readout cables and also to ensure that there are no capacitance changes with the liquid level. The variation of the reference capacitor with temperature was measured from room temperature to liquid nitrogen temperature. The capacitance of the reference capacitor changes from 12.2 pF to 11.8 pF, accordingly. The cables which connect the level meters to the UTI board go through the inner vessel and the outer vessel by vacuum feedthroughs. They are finally connected to the outside readout box with the Sub-Miniature-A (SMA) connectors.

The schematics to use mode 4 to measure the capacitance for the long level meter are shown in Fig. 4. In this mode, a 300 pF reference capacitor is used. Unlike the reference capacitor for the short level meters, here we use a commercial capacitor mounted on the evaluation

Table 1. Design parameters of the level meters. d_1 is the inner diameter of the outer tube. d_2 is the outer diameter of the inner tube. L is the length. d_f is the diameter of the nylon fishing line separating the two tubes. C_{GXe} and C_{LXe} are the theoretical capacitances assuming dielectric constant of 1.0 for gas xenon and 1.96 for liquid xenon [5] respectively.

level meters	d_1 /mm	d_2 /mm	L /mm	d_f /mm	C_{GXe} /pF	C_{LXe} /pF
<i>SLM</i>	4.5	4.0	12	0.2	5.66	10.61
<i>LLM</i>	4.5	4.0	254	0.2	119.9	232.3

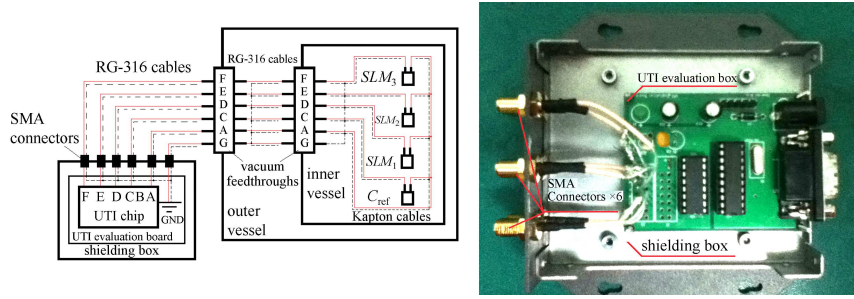

Fig. 3. (color online) Readout schematics (left) and a picture (right) showing the cable connections for the three short level meters ($SLM_{1,2,3}$) and the reference capacitor (C_{ref}).

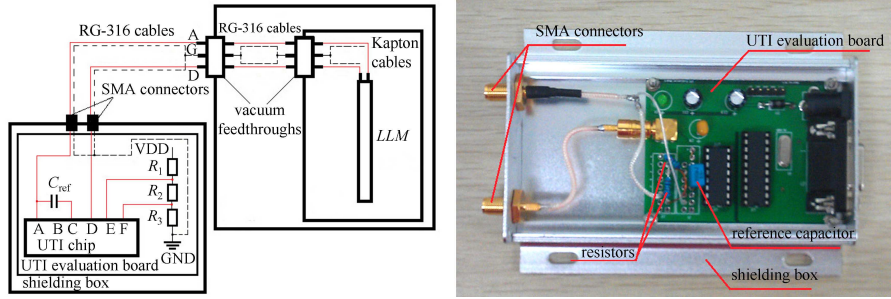

Fig. 4. (color online) Readout schematics (left) and a picture (right) showing the cable connections for the long level meter (LLM) and the reference capacitor (C_{ref}). The practical values for R_1 and R_2 are 25 k Ω and 1 k Ω respectively. R_3 is shorted in this readout mode.

board outside of the vessel, instead of near the long level meter in the liquid xenon, considering the radioactivity of the capacitor.

Coaxial cables are used to avoid capacitive-coupled interference. In Fig. 3 and Fig. 4, the red lines are signal wires of coaxial cables and the black dashed lines are their shielding layers. The shielding layers of the cables are connected together to a common wire as ground. Although the cables go through two feedthroughs, their grounding shield layers are connected together. At last, the ground wires are connected to the common ground on the UTI evaluation board.

In the inner vessel, Kapton-insulated coaxial cables from the MDC Vacuum Products Company are used [6], which satisfy the high vacuum and cryogenic requirements. For the outer vessel, which is used as a thermal insulation chamber, the requirement of vacuum is not so strict and the surrounding temperature is close to room temperature. Therefore, RG-316 cables, which are more common and cheaper, are used for connections from the inner vessel to the outer vessel. RG-316 cables are also used for the connections from the outer vessel to the readout boxes on the outside. The parasitic capacitances from the long cables (about 5 meters for each level meter), feedthroughs and the plugs add in a total capacitance about several hundreds pF. By connecting the wires to the UTI board following the schematics in Fig. 3 and Fig. 4, the parasitic capacitances are mostly

anceled.

2.3 Readout software

The capacitance measurement from the UTI chip can be read out, recorded and converted to the liquid level values by software with the UTI evaluation board connected to the computer by the RS-232 cables. Stand alone Windows-based software from Smartec Company can be used to read and record the measured values. We also developed Python-based software, which is integrated to the PandaX slow control system to read and record the data. There are slow and fast modes to read-out the capacitances. The duration of one complete cycle of the output signal for the slow mode is about 100 ms, while the fast mode gives 10 ms duration. We chose to use the slow mode in the following measurement for a better resolution.

3 Results and discussion

To check the accuracy and stability of the level meters, we performed several measurements in a small LXe system before installing the level meters in the PandaX detector. The performances of the three short level meters in a five-day operation are shown in Fig. 5 (left). The three short level meters first worked in vacuum for 47 hours. Then, liquid xenon was filled into the detector, until it completely covered the detector. The short level

meters were totally immersed in the liquid for 68 hours before the xenon was recuperated.

The mean values of the measured capacitances for the three level meters are listed in Table 2. It can be seen that the values are slightly higher than the expected theoretical values listed in Table 1. This is caused by the remaining parasite capacitances and the cumulative zero drift in the UTI board, which was especially large for the third level meter. However, it does not affect the measurement. The calibrated values, which are the capacitances per unit length, are calculated at 0.387, 0.371 and 0.380 pF/mm for the three level meters, respectively, which are about 7%–9% lower than the expected theoretical values. To calculate the height of liquid level in the PandaX detector, the measured calibration values will be used.

The measured fluctuations of capacitances represent the quality of the level meter structure and readout scheme. To quantify the stability and precision of the measurement, we use the standard deviation and peak to peak values during the entire period (68 hour) of measurement when the level meters are entirely immersed in liquid xenon. The measured values are shown in Fig. 5

(right) and listed in Table 2. The standard deviation values of the measured capacitances are between 0.005 to 0.007 pF, corresponding to a level fluctuation of less than 0.02 mm. The peak to peak values, representing the maximum fluctuation during the measured period, are 0.03 pF, corresponding to a maximum level readout fluctuation of less than 0.1 mm.

For the long level meter measurement, the first measurement showed a maximum level fluctuation (L_{P2P}) up to several millimeters (see the blue dashed line in Fig. 6), which was too large to satisfy the requirement of the experiment. After changing the electrical components on the readout board, we found that the quality of the reference capacitor dramatically affects the precision of the measurement. The reference capacitor that we then used was the 300 pF PFR series capacitor from Evox Rifa company. The resistors were replaced with high precision ($\pm 0.1\%$ Ω) 0.25 W metal film resistors (RJ14) and low-temperature-drift (15–25 ppm/ $^{\circ}\text{C}$) type to further improve the measurement. The performance of the long level meter measurement after changing the reference capacitor and resistors is shown as the red line in Fig. 6.

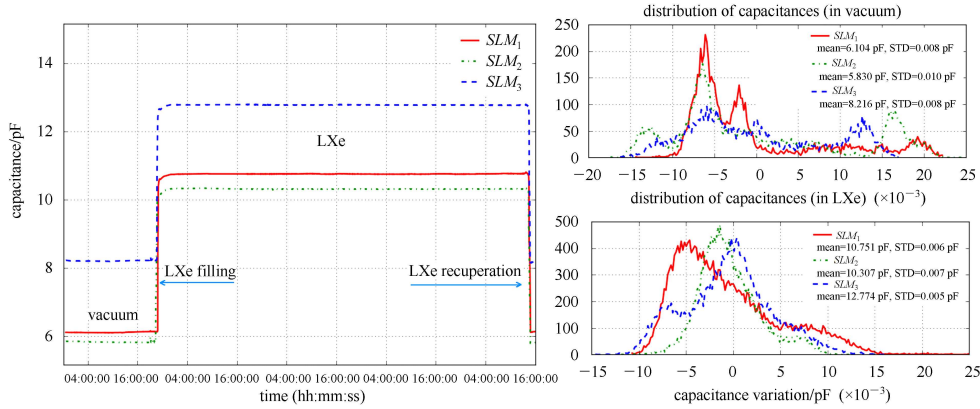

Fig. 5. (color online) Left: Measured capacitances of the three short level meters ($SLM_{1,2,3}$) during a five-day operation in a LXe system. Right: Distributions of the measured capacitances, subtracting their mean values, for these level meters in vacuum and in liquid xenon. The mean and standard deviation (STD) values during the respective periods are listed in the figure legends.

Table 2. Measured capacitances and their fluctuations of the three short level meters ($SLM_{1,2,3}$) and one long level meter (LLM). C_{vac} and C_{LXe} are the mean capacitance values when the level meters are in vacuum or fully immersed in liquid xenon respectively. The calibration value is the capacitance per unit length. C_{STD} and L_{STD} are the standard deviation values of capacitances and corresponding levels when the level meters are in liquid xenon during the measurement periods. C_{P2P} and L_{P2P} represent the largest fluctuations for the capacitances and corresponding levels during the measurement periods.

level meters	C_{vac}/pF	C_{LXe}/pF	calibration/ (pF/mm)	C_{STD}/pF	L_{STD}/mm	C_{P2P}/pF	L_{P2P}/mm
SLM_1	6.104	10.751	0.387	0.006	0.016	0.028	0.09
SLM_2	5.830	10.307	0.371	0.007	0.019	0.025	0.07
SLM_3	8.216	12.774	0.380	0.005	0.013	0.031	0.08
LLM	120.0	213.4	0.37	0.05	0.14	0.20	0.53

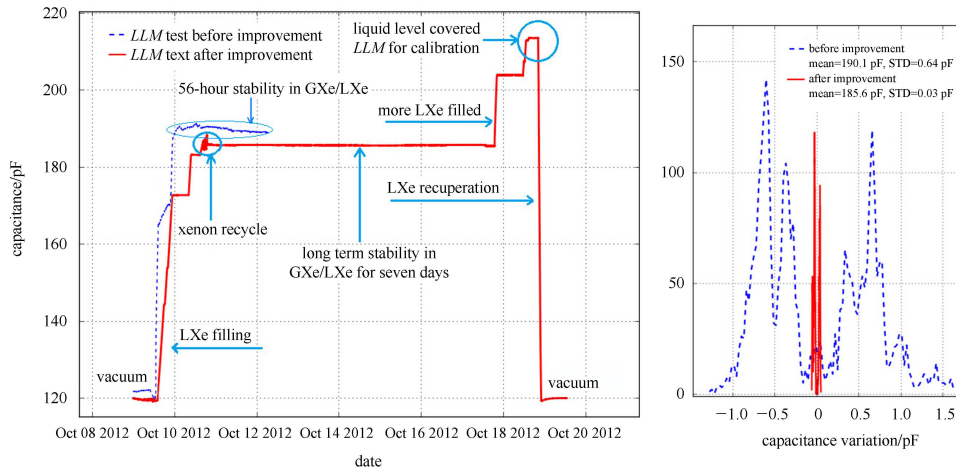

Fig. 6. (color online) Left: Measured capacitances of the long level meter in a LXe system. A replacement of the reference capacitor significantly improved the stability of measurement. The blue dashed line shows the data before the improvement and the red line shows the data after the improvement. Right: Distributions of the measured capacitances, after subtracting their mean values for the long level meter when the liquid xenon was in a stable condition. The reduction of the readout fluctuation is clear from the figure. The standard deviation value is reduced from 0.64 to 0.03 pF after the improvement.

After these improvements were made the standard deviation value of the measured capacitance was 0.05 pF, corresponding to a 0.14 mm level fluctuation when the long level meter was in a stable liquid xenon for seven days. The maximum fluctuation during the seven days is 0.2 pF (or 0.53 mm). After seven days of operation, we filled the detector with more liquid xenon to completely cover the long level meter. Using the capacitance value measured when it is fully immersed in liquid xenon and in a vacuum, we derived a calibration value of 0.37 pF/mm for the long level meter.

4 Conclusion

In this paper, we present a detailed design and development of the liquid level meters that are used in the PandaX dark matter detector. Three short level meters to monitor the inclination of the TPC and one long level

meter to monitor the overall liquid xenon level are developed. Special care was taken over the cable connections and selection of the reference capacitors and resistors, which are critical for the stability and precision of the level measurement. The fluctuations (standard deviation) are less than 0.02 mm for the short level meters in a 68 hour test measurement, and is 0.14 mm for the long level meter in a seven-day measurement. The maximum fluctuations (peak to peak) during the corresponding periods are less than 0.1 mm for the short level meters and 0.53 mm for the long level meter. The developed level meters and their readout method thus satisfy the requirements of the experiment and they have been installed in the PandaX detector.

We would like to thank Dr. Angel Manzur for his valuable inputs and the other members of the PandaX collaboration for their useful discussions during the work.

References

- GONG H, Giboni K L, JI X, TAN A, ZHAO L. The Cryogenic System for the PandaX Dark Matter Search Experiment, 2013 JINST 8 P 01002 [arXiv:1207.5100]
- Aprile E, Alfonsi M, Arisaka K et al. (XENON100 collaboration). Phys. Rev. Lett., 2012, **109**: 181301 [arXiv:1207.5988]
- Plante G. The XENON100 Dark Matter Experiment: Design, Construction, Calibration and 2010 Search Results with Improved Measurement of the Scintillation Response of Liquid Xenon to Low-Energy Nuclear Recoils. PhD Thesis. Columbia University, New York, 2012
- Smartec Company. <http://www.smartec-sensors.com/en/products/uti-interface-en.html>
- Schmidt W F. The Basic Properties of Liquid Xenon as Related to its Application in Radiation Detectors, in Technique and Application of Xenon Detectors. Proceedings of the International Workshop. Edited by Suzuki Y, Nakahata M, Koshio Y, Moriyama S. Singapore: World Scientific, 2002
- MDC Vacuum Products. <http://www.mdcvacuum.com/displaypart.aspx?p=680502>