

Simulation of a Transverse Feedback System for the SSRF Storage Ring^{*}

JIANG Bo-Cheng^{1,2} LIU Gui-Min¹ ZHAO Zhen-Tang^{1:1)}¹ (Shanghai Institute of Applied Physics, CAS, Shanghai 201800, China)² (Graduate University of Chinese Academy of Sciences, Beijing 100049, China)

Abstract Resistive wall instability is a serious problem in many light sources. An active transverse feedback system (TFS) is required to operate the machine in a good condition when beam current is high. In order to investigate beam dynamics with TFS turned on, we developed a TFS simulation program. The feedback effectiveness for the Shanghai Synchrotron Radiation Facility (SSRF) storage ring is simulated under various conditions such as closed orbit distortion included, beam position monitor reading errors added, and finite-duration impulse-response filter strategy changed.

Key words SSRF, feedback, simulation, accelerator toolbox (AT)

1 Introduction

Shanghai Synchrotron Radiation Facility (SSRF) is a 3rd generation synchrotron light source based on a 3.5GeV and 300mA storage ring. The ring vacuum chamber with octagonal (68mm×35mm) cross section is made of stainless steel. When the SSRF storage ring is filled uniformly with 720 bunches, its resistive wall instability threshold in the vertical plane is only about 70mA when chromaticity is zero. Some of the most dangerous instability modes are listed in Table 1. Although, increasing the chromaticity could raise the transverse instability threshold^[1], it will strongly impact the injection efficiency^[2], reduce the dynamic apertures and the beam lifetime^[3]. Furthermore, narrow-gap insertion devices would be installed in the ring which will make the instability even severe.

Table 1. Growth time of resistive-wall instability.

| | | | | | |
|----------------|------|------|------|------|------|
| mode number | 708 | 707 | 706 | 705 | 704 |
| growth time/ms | 1.68 | 2.65 | 3.34 | 3.92 | 4.42 |

So the implementation of a transverse feedback system (TFS) is an imperative step towards overcoming the instabilities for normal operations.

TFS techniques have been developed over decades. There are mainly two types of systems^[4]: One is the frequency domain feedback system called mode-by-mode TFS which detects each unstable mode and damps each unstable mode with a single narrowband feedback channel. If there are N unstable modes, N parallel feedback channels are needed. In advanced light sources, there are hundreds or even thousands of unstable modes. The mode-by-mode system is not manageable under those conditions. With the progress of the fast electronics, another time domain feedback system^[5–8] called bunch-by-bunch TFS was developed which extracts the signal of each bunch and kicks any bunch with a proper deflection. It can damp the oscillations of all bunches no matter how many of them are stored in the ring. In order to operate the bunch-by-bunch system effectively, the bandwidth of the system should larger than half of

Received 27 November 2006

^{*} Supported by the SSRF Project

1) E-mail: Zhaozt@ssrc.ac.cn

the bunch frequency.

For investigating the dynamic process, some simulation work have been done in the past few years^[9–11]. In this paper, we take a further step to simulate TFS by tracking the particle through the whole ring and processing the real time signals with a signal process block. Doing such a work is time consuming, however it's worthwhile. It could help to guide the design of TFS, set hardware requirements and understand the beam dynamics in further details.

2 Simulation model

A Bunch-by-bunch TFS has been designed for the SSRF storage ring. The block diagram of the TFS is shown in Fig. 1. In our simulations, only the vertical resistive wall instability and vertical TFS are treated.

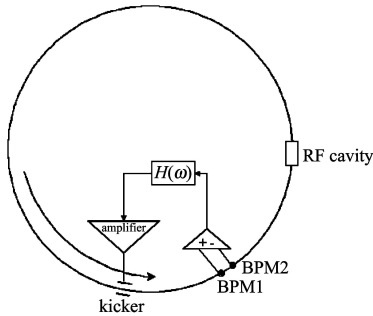

Fig. 1. Block diagram of SSRF TFS.

The betatron phase advance of the signal from beam position monitor (BPM) to the kicker should be about $2n\pi - \pi/2$ which gives the most rapid damping rate (n is an integer). Two BPMs are used in our case to generate a proper signal for the kicker wherever it is installed. The betatron phase advances between two BPMs in both the horizontal and vertical planes are around $\pi/2$, such orthogonal signals are convenient to compose signals of any phase advance we needed. The kicker is installed at the end of a long straight section where β function is relatively large and is more efficient for kicking.

A simplified flow chart of the simulation code for the TFS is shown in Fig. 2. The code is based on 6D tracking program accelerator toolbox (AT)^[12].

As the coupled bunch instability is treated, we use a macroparticle representing a bunch. The initial coordinates of the bunches are set by random numbers near 'ideal' particles. Before simulation, the lat-

tice of the ring is prepared including setting the misalignments of elements in the ring, calculating the transform matrixes of ordinary elements, indicating TFS BPMs, defining the wake-field-elements and the kicker. The 'pass elements' subroutine is provided by AT itself, including all the basic transform matrixes of the elements such as RF cavities, bending magnets, quadrupoles and sextupoles. There are two dynamic elements that should be treated specially when bunches pass through the ring: one is the wake-field-element whose force depends on transverse positions of previous bunches and previous turns (according to the limited computer ability, only previous 10 turns of wake fields are counted); the other is the kicker whose force depends on transverse positions of the same bunch at the place of TFS BPMs and on the signal process.

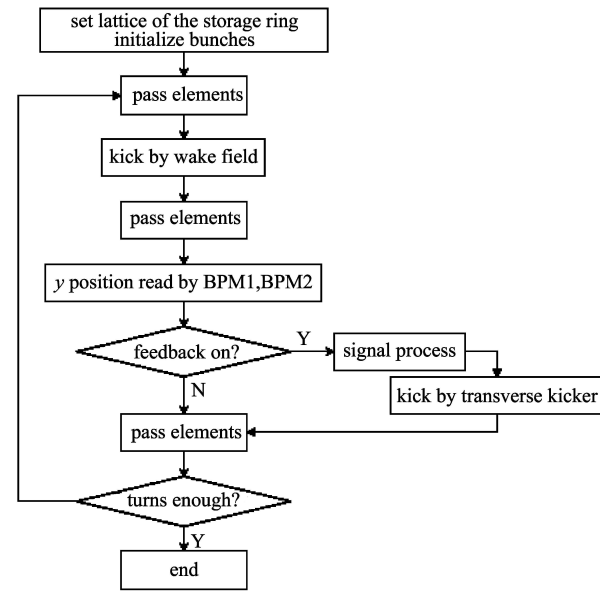

Fig. 2. Flow chart of the TFS.

Strictly speaking, the wake fields of the resistive wall should be distributed all along the ring. However it is difficult to achieve as the ability of the computer is limited. So the wake fields are lumped at a few places. The deflection caused by the wake is given by^[13]:

$$dy'_{\text{wake}} = -\frac{eV_{\perp}}{\gamma m_0 c^2} = -\frac{e}{\gamma m_0 c^2} \frac{2L}{\pi b^3} F \sqrt{\frac{c}{\sigma}} \sum_n \frac{Q_n y_n}{\sqrt{z_n}}, \quad (1)$$

where e is the electron charge, γ is the relative energy, m_0 is the mass of the electron, c is the velocity of the

light, L is the length of the chamber, b is the equivalent chamber radius, F is the shape factor, σ is the conductivity of the chamber metal, Q_n, y_n, z_n denote previous bunch charges, transverse offsets and distance apart from the present bunch respectively.

At the place of transverse kicker, the bunch receives a deflection which is given by the following expression:

$$dy'_{\text{kicker}} = A \frac{V_k e}{E} dy = A \frac{(\sqrt{P \times 2R}) e}{E} dy, \quad (2)$$

where dy'_{kicker} is the deflection caused by kicker, dy is the transverse position detected by TFS BPMs. A is the amplifier factor, E is the particle energy, P is the power of the amplifier, R is the shunt impedance of the kicker which is assumed to be a frequency-domain constant in our calculations for convenience.

The response voltage of the BPM $S(t)$ is read from a file which is calculated by Mafia beforehand. Then the signals from BPMs normalized by charge Q can be easily created by $S(t) \times y(s)$ which will be input to the following signal process.

The signal process mainly includes two band pass filters which filter the 1.5GHz BPM signals, two mixers which mix the BPM signals with 3rd harmonic RF signals, two low pass filters demodulate signals to 500MHz, two vectors which generate proper signals, a FIR filter which rejects DC signals caused by closed orbit distortion (COD) or TFS BPM offsets and some delay lines. The diagram of signal process and the signals in time domain is sketched in Fig. 3.

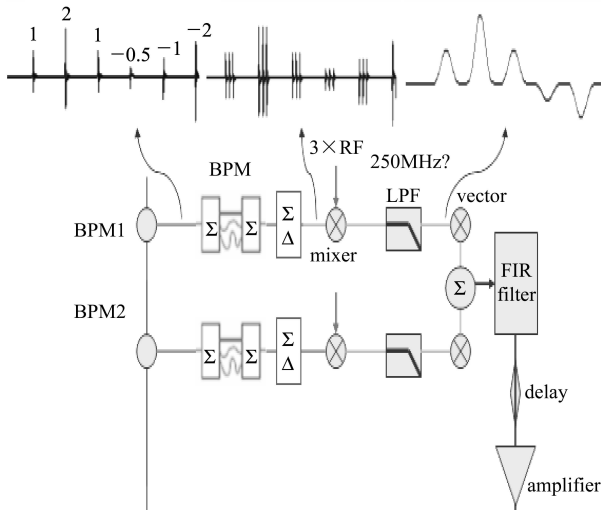

Fig. 3. Diagram of signal process block and signals.

The finite-duration impulse-response (FIR) filter is a key component for the TFS signal process system. With rapid advances of digital signal process technologies, using digital higher order tap FIR is a tendency. However, the algorithm for the FIR coefficients is still a matter of choice.

Assuming the output of the M -tap FIR filter has the form of ^[14]

$$y(n) = \sum_{k=n}^{n-M+1} h_k x(k) = \sum_{k=0}^{M-1} h_k \left(\sum_m [A_m \sin(k\nu_m + \varphi_m)] + D + N(\text{random}) \right). \quad (3)$$

The frequency response of the filter is

$$H(\omega) = \sum_{k=0}^{M-1} h_k e^{-j\omega k}. \quad (4)$$

where m denotes the modes of the oscillations, h is the coefficients to be determined, A_m, ν_m are the mode amplitude and tune respectively. D is the DC signal caused by COD or TFS BPMs offsets, N is the noise.

Here, some basic principles for calculating the FIR coefficients should be pointed out.

1) Most important, the filter should filter the DC signal which gives out the restriction

$$\sum_k h_k = 0. \quad (5)$$

2) The filter should tolerate the tune shift which gives

$$\left. \frac{\partial H(\omega)}{\partial \omega} \right|_{\omega=\nu_m} = 0. \quad (6)$$

Also, there are some other restrictions which could be chosen.

3) Set a fixed response amplitude at the frequency of the modes

$$|H(\omega = \nu_m)| = 1. \quad (7)$$

4) In order to reduce effects of noise, we can create a band pass filter which can be defined as

$$H(\omega = \nu_b) = 0, \quad (8)$$

here ν_b is the frequency chosen between the tunes of the modes.

Different restrictions create different coefficients and give different results. We should note that Equations (5), (6) and (7) could create a coefficient cal-

ulation matrix that is similar to the matrix created by the time domain least square fitting (TLSR) method developed by T.Nakamura^[14]. Some of the FIR strategies will be compared below by simulations.

3 Simulation results and analyses

The SSRF storage ring is composed of 20 DBA cells^[15]. The main parameters are listed in Table 2. The chromaticity of the lattice is tuned to zero in our simulations. The misalignments have been added to the magnets with standard deviation of the dipoles, quadrupoles and sextupoles offset misalignment value 0.2mm and quadrupole roll misalignment value 0.2mrad. Occasionally, the COD for some seeds is large, which makes the beam lost rapidly. A COD correction code based on SVD algorithm^[16] is used to suppress the COD.

Table 2. Main parameters of the SSRF storage ring.

| | |
|--------------------------------------|-----------------------|
| beam energy | 3.5GeV |
| circumference | 432m |
| emittance | 3.90nm-rad |
| betatron tunes Q_x/Q_y | 22.22/11.32 |
| synchrotron tune Q_s | 7.17×10^{-3} |
| natural chromaticities ξ_x/ξ_y | -54.3/-18.3 |
| harmonic number | 720 |
| RF frequency | 499.654MHz |
| RF voltage | 4.0MV |
| damping times $\tau_x/\tau_y/\tau_s$ | 6.95/6.97/3.49ms |
| β_y^* at BPMs/kicker | 6.46m/11.5m |
| power for kicker amplifier | 300W(design value) |
| shunt impedance of kicker | 21.6k Ω |

* Beta function.

Figure 4 shows the tracking result of a bunch oscillation amplitude and major tune in the vertical plane when the beam current is 300mA. The feedback system is turned on after 1000 turns. The simulation result is satisfactory. The damping time of the feedback system is about 0.36ms. It almost catches the analytical result, which is given by the following formula

$$\tau_{\text{FB}} = \frac{2T_0 E \cdot y_{\text{max}}}{V_k e \sqrt{\beta_{\text{pick}} \beta_{\text{kick}}}}, \quad (9)$$

where T_0 is the revolution period, $y_{\text{max}}=1\text{mm}$ is the maximum amplitude of the bunch that TFS could damp, β_{pick} and β_{kick} are the beta functions at the

place of TFS BPMs and kicker respectively. Using SSRF parameters gives the result $\tau_{\text{FB}} \approx 0.32\text{ms}$.

As the vertical oscillation is suppressed by the feedback system, the bunch motion dominated by the horizontal oscillation coupled to the vertical plane. The maximum spectrum peak then changes from $0.32\omega_0$ to $0.22\omega_0$ as has been shown in Fig. 4(b).

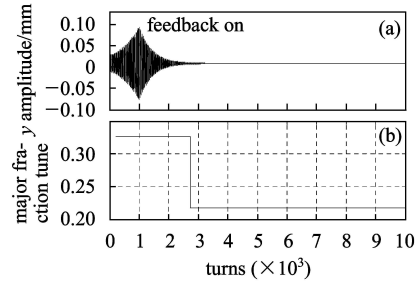

Fig. 4. Oscillation amplitude and major tune of a bunch.

With 300W amplifier power, the maximum current that could be stored in the ring is about 1800mA with feedback on.

3.1 Effects of COD

Several lattice seeds with random misalignment have been tested. After sufficient turns of feedback,

Table 3. SSRF TFS simulation results for different lattice seeds (a bunch train with 300mA current composed by 5 bunched is used).

| seed number | COD value (at BPM1, 2 and wake)/mm | | | rms value of convergence value/ μm |
|-------------|------------------------------------|-------|-------|---|
| 01* | -0.01 | 0.1 | 0.14 | 0.686 |
| 02* | -0.02 | 0.05 | -0.16 | 0.771 |
| 03* | 0.008 | 0.014 | 0.03 | 0.161 |
| 04 | 0.10 | -0.11 | 0.81 | 3.88 |
| 05 | -0.09 | 0.10 | 0.64 | 3.22 |
| 06 | -0.10 | -0.10 | 0.37 | 2.04 |
| 07 | 0.10 | 0.10 | -0.09 | 0.797 |
| 08 | 0.11 | -0.10 | 0.61 | 3.04 |
| 09 | -0.09 | 0.10 | 0.64 | 3.16 |
| 10 | -0.11 | 0.10 | -0.63 | 3.17 |
| 11 | -1.0 | 0.50 | -0.37 | 1.90 |

*The first 3 seeds are COD corrected by 80 COD kickers.

the oscillations will converge to a certain value with the amplitude tending to zero. However, when the ring is filled with a bunch train, the convergence values of bunches are different from each other. This is caused by the different wake fields felt by bunches in the bunch train. The rms value of the convergence values strongly depends on the COD value where

wake field is added. The simulation results are shown in Table 3 where a simple 2-tap FIR filter is used.

The effect of DC current caused by COD or BPM offset is a major concern for the TFS design. But the DC current effects have not been observed in the simulation results. The main reason may lie in the fact that the FIR filter for the simulation is such an ideal one that all the DC currents can be removed thoroughly.

3.2 Effect of BPM errors

To test the BPM reading error tolerance of the TFS, the white Gauss noises (WGN) were added to the bunch transverse positions read by the TFS BPMs. The first three seeds were checked. The residual fluctuations of the bunch motions are shown in Fig. 5. The system can provide about -13dB (0.24 times) damping to the reading errors, which is worse than the theoretical result given by^[17],

$$\frac{\sigma_y}{\sigma_\delta} = (\sqrt{T_0\tau}/\tau_{\text{FB}})G(v), \quad (10)$$

where $\sigma_{y,\delta}$ are the rms values of the residual fluctuations and noises respectively. $\tau \approx \tau_{\text{FB}}$ is the total damping time, $G(v) \approx 1$ is the gain of FIR filter. The formula gives about -24dB (0.06 times) damping.

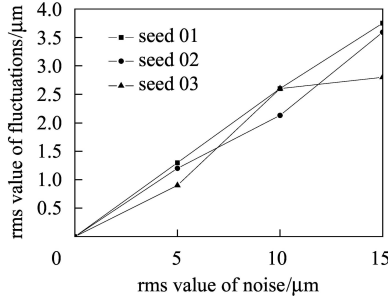

Fig. 5. rms value of residual fluctuations.

From the simulations, we find out that the resolution of the TFS BPMs should be better than $4\mu\text{m}$. A higher order FIR filter to suppress the noises is desired for the TFS.

3.3 FIR coefficients

Some kinds of FIR strategies have been compared in the simulations. The 2-tap FIR coefficients are $h_0 = 0.5$, $h_2 = -0.5$. The 9-tap FIR coefficients are

calculated with restrictions Equations (5), (6) and (7) (where ν_m means ν_y). Additionally, Method 1 with restrictions

$$\left. \frac{\partial H(\omega)}{\partial \omega} \right|_{\omega=2\nu_y} = 0, \quad (11)$$

$$\left. \frac{\partial H(\omega)}{\partial \omega} \right|_{\omega=3\nu_y} = 0. \quad (12)$$

Method 2 with restrictions

$$H(\omega = 0.5\nu_y) = 0, \quad (13)$$

$$H(\omega = 1.5\nu_y) = 0 \quad (14)$$

and Method 3 with restrictions

$$\left. \frac{\partial H(\omega)}{\partial \omega} \right|_{\omega=\nu_x} = 0, \quad (15)$$

$$H(\omega = 0.2\pi) = 0. \quad (16)$$

The results are shown in Table 4.

Table 4. Different FIR coefficients strategies for TFS (Seed 01).

| rms value of noise/ μm | rms value of residual fluctuations/ μm | | | |
|-----------------------------------|---|-----------|----------|----------|
| | 2-tap FIR | 9-tap FIR | | |
| | | method 1 | method 2 | method 3 |
| 5 | 1.3 | 0.75 | 0.74 | 0.76 |
| 10 | 2.6 | 1.68 | 1.37 | 1.51 |
| 15 | 3.75 | 2.24 | 2.06 | 2.27 |

It's obvious that 9-tap FIR filters are better than 2-tap FIR filter. Among 3 types of 9-tap FIR filters, method 2 seems more efficient comparing to the remainders. method 2 is a band pass filter with frequency response shown in Fig. 6. The band pass filter could filter the WGN more effectively, and thus would get a better result. As the order of the FIR gets higher, the freedom increases and the problem becomes more complex. Further investigations should be done for the choice of FIR coefficients.

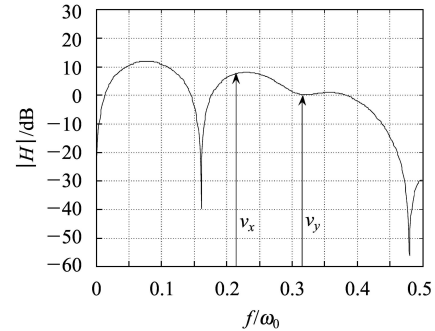

Fig. 6. Frequency response of the FIR filter.

4 Conclusion

A transverse feedback system is required for SSRF. Based on the simulation code developed at SSRF, comprehensive simulations of the resistive wall instability and transverse feedback system have been

done. The simulation results match with theoretical prediction and give a confirmation of the SSRF TFS design. With TFS turned on, the current threshold reaches 1800mA when the vertical resistive wall instability is added. TFS with 2-tap FIR filter could only give a -13dB damping to the BPM reading errors, a better FIR filter is desired for the SSRF TFS.

References

- 1 Sacherer F. Transverse Bunched Beam Instabilities-Theory. Proc. 9th Int. Conf. on High Energy Accelerators. Stanford, 1974, 347
- 2 Tanaka H et al. J. Synchrotron Rad., 2006, **13**: 378
- 3 JIANG Bo-Cheng et al. HEP & NP, 2006, **30**(7): 693 (in Chinese)
(姜伯承等. 高能物理与核物理, 2006, **30**(7): 693)
- 4 Fox J D. Feedback Control of Coupled-Bunch Instabilities. Proceedings of PAC93. Washington D.C., 1993, 2076
- 5 Barry W, Byrd J M et al. Design of the ALS Transverse Coupled-Bunch Feedback System. Proceedings of PAC93. Washington D.C., 1993, 2109
- 6 Barry W, Byrd J M et al. Design of the PEP-II Transverse Coupled-Bunch Feedback System. Proceedings of PAC95. Dallas, 1995, 2681
- 7 Khan S, Knuth T et al. Longitudinal and Transverse Feedback Kicker for the BESSY II Storage Ring. Proceedings of PAC99. New York, 1999, 1147
- 8 Fox J D et al. Multi-Bunch Instability Diagnostics via Digital Feedback System at PEP-II, DAΦNE, ALS and SPEAR. Proceedings of PAC99. New York, 1999, 636
- 9 Byrd J M. Simulation of the PEP-II Transverse Coupled-Bunch Feedback System. Proceedings of PAC1995. Dallas, 1995, 2684
- 10 Bressanutti R, Bulfone D et al. Design Considerations for the ELETTRA Transverse Multi-Bunch Feedback. Proceedings of PAC99. New York, 1999, 1120
- 11 Wolski A, Byrd J, Bates D. Simulations of Resistive-Wall Instability in the ILC Damping Rings. Proceedings of PAC2005. Knoxville, 2005, 3241
- 12 Terebilo A. SLAC-PUB-8732, May 2001
- 13 Alexander Wu Chao. Physics of Collective Beam Instabilities in High Energy Accelerators. John Wiley&Sons, 1993
- 14 Nakamura T et al. Single-loop Two-Dimensional Transverse Feedback for Photon Factory. Proceedings of EPAC2006. Edinburgh, 2006, 3006
- 15 LIU Gui-Min et al. HEP & NP, 2006, **30**(Supp.I): 144 (in Chinese)
(刘桂民等. 高能物理与核物理, 2006, **30**(增刊I): 144)
- 16 HOU Jie, LIU Gui-Min. HEP & NP, 2006, **30**(Supp.I): 37 (in Chinese)
(后接, 刘桂民. 高能物理与核物理, 2006, **30**(增刊I): 37)
- 17 Nakamura T et al. Transverse Bunch-by-bunch Feedback System for the Spring-8 Storage Ring. Proceedings of EPAC2004. Switzerland, 2004, 2649

上海光源储存环横向反馈系统模拟计算*

姜伯承^{1,2} 刘桂民¹ 赵振堂^{1;1)}

1 (中国科学院上海应用物理研究所 上海 201800)

2 (中国科学院研究生院 北京 100049)

摘要 在同步辐射光源中, 阻抗壁不稳定性是一个很严重的问题. 要保证储存环在高流强下正常运行, 就需要安装一套横向反馈系统. 为了了解在横向反馈作用下束流的动力学性质, 建立了一套横向反馈模拟计算程序. 并用该程序模拟计算了上海光源储存环横向反馈系统在闭轨误差(COD)、束流位置探测器读数误差以及梳状滤波等条件改变下的反馈效果.

关键词 上海光源 反馈 模拟 加速器函数工具箱

2006 - 11 - 27 收稿

* 上海光源工程资助

1) E-mail: Zhaozt@ssrc.ac.cn